

Problem 1 and 2 Consider the following operational amplifier. The goal is to obtain an expression for the small-signal output voltage in terms of the input variables V_{IN}^+ and V_{IN}^- .

- Write a complete set of small-signal equations that can be solved to obtain V_{OUT} . Assume the small-signal parameter g_o is present in all MOS devices.
- Solve these equations by hand for V_{OUT} but, if you do not have a solution at the end of ½ hour, stop, and comment on your progress and the amount of effort that you believe would be required to finish the solution.
- Obtain a parametric (symbolic) solution for the transfer function V_{OUT}/V_{IN} from this set of equations with MATLAB. This solution will be the ratio of two polynomials in s . Each coefficient will be comprised of the sum of a number of product terms. How many total product terms appear in this solution? In this part, $V_{in} = V_{in}^+ - V_{in}^-$
- Simplify the solution obtained with MATLAB under the assumption that all g_o terms are small compared to g_m terms

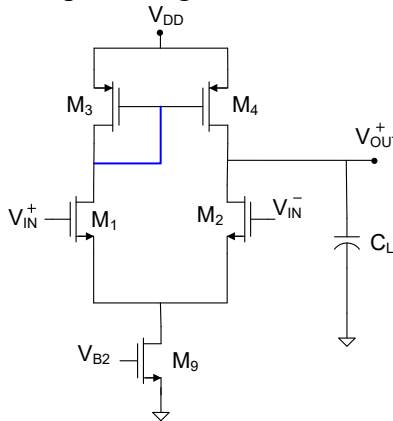

Problem 3 A transresistance amplifier with a gain R_T is shown. Derive an expression for the voltage gain of the amplifier as a function of the transresistance gain R_T and determine what that reduces to if R_T is very large.

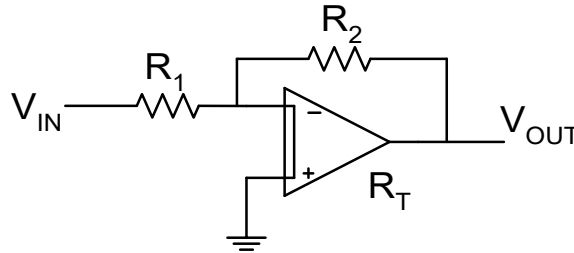

Problem 4 Assume the amplifier shown below is designed in a $0.18\mu\text{m}$ CMOS process with model parameters $\mu\text{C}_{\text{OX}}=250\mu\text{A}/\text{V}^2$, $\lambda=0.01\text{V}$, and $V_{\text{THn}}=0.4\text{V}$. Assume $V_{\text{DD}}=1\text{V}$, $V_{\text{SS}}=-1\text{V}$, and $I_{\text{DQ}}=4\text{mA}$.

a) Analytically determine the W and L needed to establish a quiescent output voltage of 0.5V when $V_{\text{INQ}}=0.5\text{V}$.

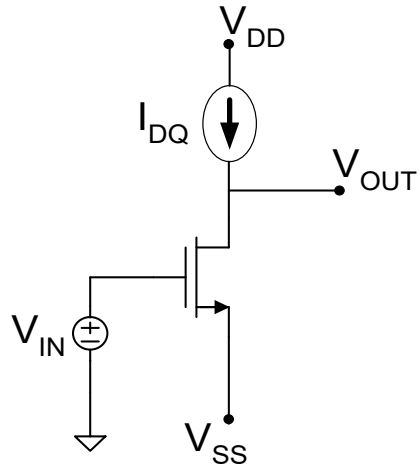

- b) Verify the transfer characteristics by Spice simulation.
- c) Analytically determine the dc voltage gain at the Q-point established in a)
- d) Using SPICE, obtain a plot of the small signal voltage gain versus the quiescent output voltage.

Problem 5 and 6 Design a 5T op amp to have a dc gain of 50dB and a GB of 2MHz in the TSMC $0.18\mu\text{m}$ CMOS process. Assume $V_{\text{DD}}=3.5\text{V}$ and $C_{\text{L}}=1\text{pF}$. Assume also that the bias voltages V_{B1} and V_{B2} can be precisely set so that a CMFB circuit is not needed. Verify the gain and the GB of your design with a SPICE simulation.

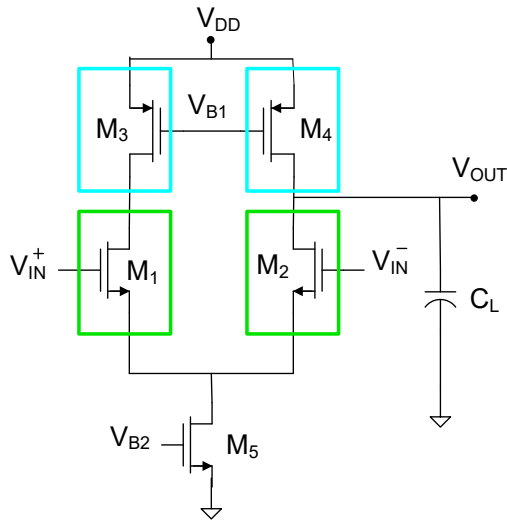

Problem 7

Assume the input to the following circuit is $V_{IN}=5\sin 10^4 t$.

- Determine the RMS noise voltage at the output assuming the components in the circuit are operating at 300K.
- Determine the desired output voltage.
- What is the signal to noise ratio at the output.

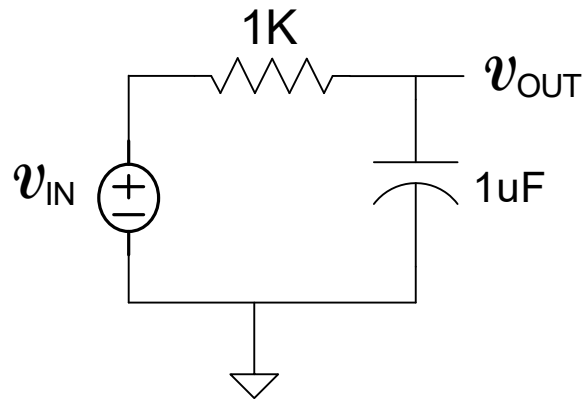

Problem 8

Consider the following amplifier designed in a 0.18μ CMOS process with model parameters $\mu_{COX}=250\mu AV^{-2}$, $\lambda=0.01V$, and $V_{THn}=0.4V$ with $V_{DD}=2V$ and $V_{SS}=-1V$ operating at $T=300K$.

- If the transistor M_1 has $L=2\mu m$, determine W so that $I_{DQ}=10\mu A$.
- With the transistor sized as in part a), determine the RMS noise voltage v_{OUT1} if S_1 is open. Consider only the thermal noise of the MOSFET and resistor.
- With S_1 closed, determine the RMS noise voltage at v_{OUT2} . (again considering only the thermal voltage of the MOSFET and resistor).
- Comment on what the lowpass filter had done to the noise voltage at the output.

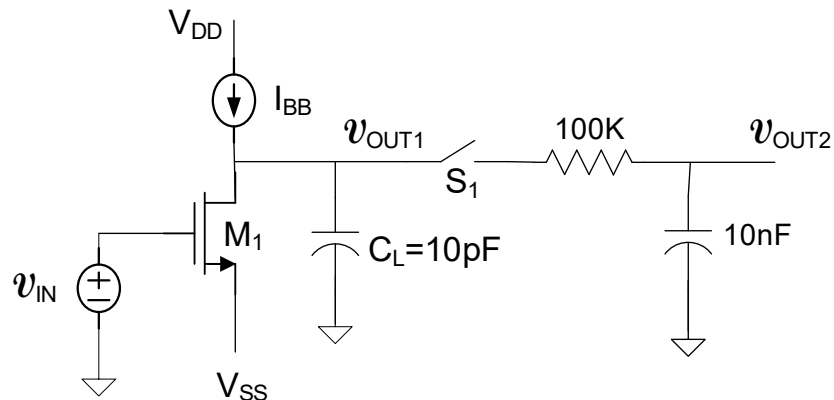

Problem 9 Assume that the op amp is a single-pole amplifier with gain given by the expression $A(s) = \frac{A_0\omega_A}{s + \omega_A} \cong \frac{GB}{s}$ where the gain-bandwidth product of the op amp is

$GB = A_0\omega_A$. The right-most approximation to the gain is almost always justifiable when used to characterize the operational amplifier since the gain of the op amp is so large at dc and since at frequencies even modestly above ω_A , there is little difference between the middle term and the right term in this expression.

a) Assuming that the frequency-dependent gain of the op amp can be modeled as $A(s) \cong \frac{GB}{s}$, determine the transfer function $A_{FB}(s) = \frac{V_{OUT}(s)}{V_{IN}(s)}$ for the following two amplifiers

b) With the same op amp model used in part a), analytically determine the 3dB bandwidth of the following two amplifiers.

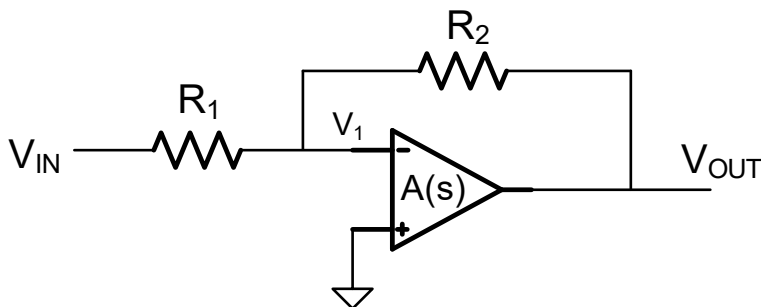
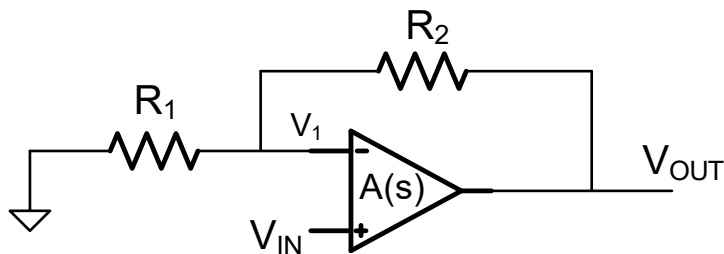

Problem 10 (Extra Credit) The “dead network” of a circuit is obtained by setting all small-signal inputs to 0. That is, by replacing all ac voltage sources with short circuits and all ac current sources with open circuits. The β of a feedback amplifier is a characteristic of the “dead network”. Consider the basic inverting and noninverting feedback amplifiers shown below. These are widely used as small-signal voltage amplifiers.

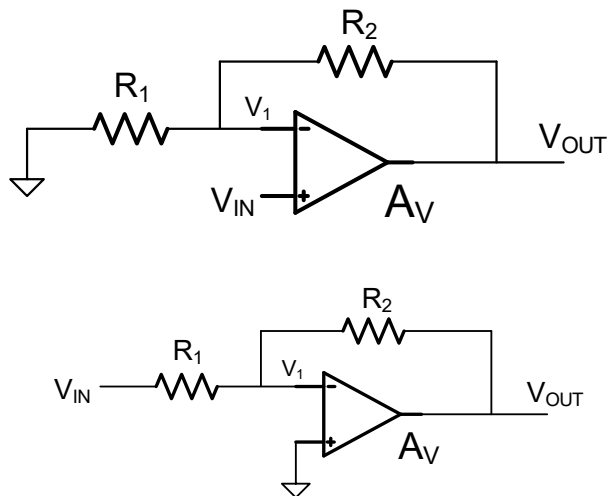

- Show that they both have the same “dead network”
- The β of the two amplifiers shown is $\beta = \frac{R_1}{R_1 + R_2}$. Show that the gain of the noninverting feedback amplifier can be expressed by the standard feedback equation

$$A_{VF} = \frac{V_{OUT}}{V_{IN}} = \frac{A_V}{1 + A_V \beta}$$

- Take the limit as A_V goes to ∞ for the gain derived in part b) and compare with that derived in EE 230 for the gain of the noninverting feedback amplifier.
- Derive the gain of the inverting feedback amplifier in terms of A_V and β and comment on why it does not look like the standard feedback equation.